



ENIDINE non-adjustable micro-bore hydraulic shock absorbers can accommodate varying energy conditions. This family of tamperproof shock absorbers provides consistent performance, cycle after cycle. Non-adjustable models are designed to absorb maximum energy within a compact envelope size.

The **TK Series** is a versatile, miniature design which provides effective, reliable deceleration and vibration control for light loads. Models can accommodate a wide range of operating conditions.

The Enidine **STH Series** offers the highest energy absorption capacity relative to its size. These custom-orificed shock absorbers are designed to meet exact application requirements. STH Series shock absorbers are available in fully threaded cylinder bodies, providing flexibility in mounting configurations.

Features and Benefits

- Extensive non-adjustable product line offers flexibility in both size and energy absorption capacity to fulfill a wide range of application requirements.
- Tamperproof design ensures repeatable performance.
- Special materials and finishes can be designed to meet specific customer requirements.
- Incorporating optional fluids and seal packages can expand the standard operating temperature range from (15°F to 180°F) to (-30°F to 210°F).
- Threaded cylinders provide mounting flexibility and increase surface area for improved heat dissipation.
- A select variety of surface finishes maintains original quality appearance and provides the longest corrosion resistance protection.
- ISO quality standards result in reliable, long-life operation.

Non-Adjustable Series Hydraulic Shock Absorbers

TK, STH Micro-Bore Series

Overview

Enidine Non-Adjustable Single-Orifice Shock Absorbers

Non-Adjustable Series

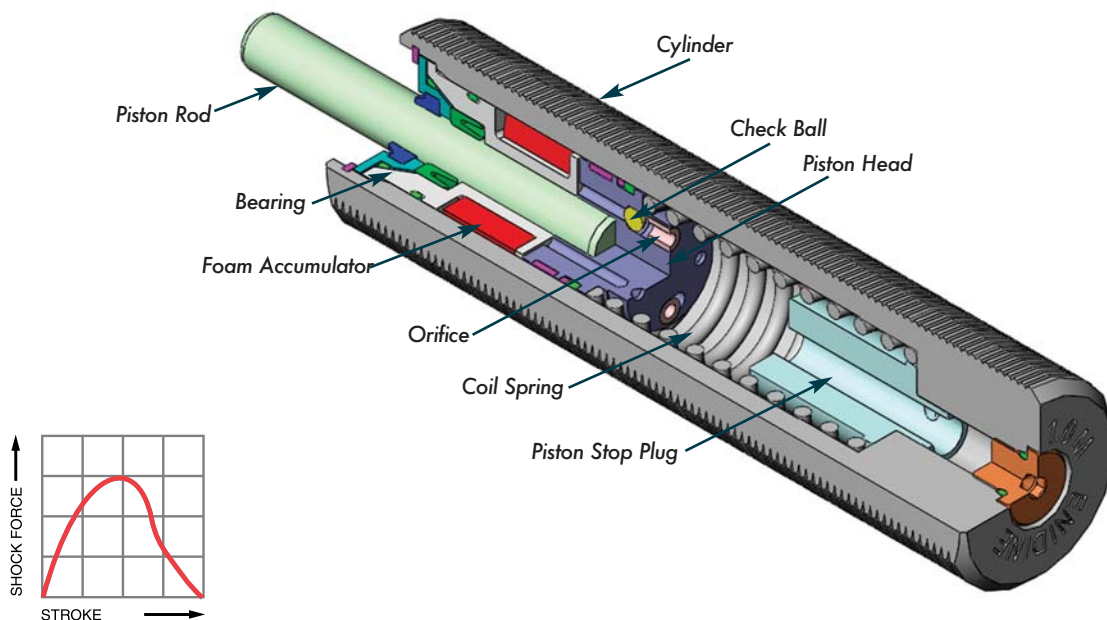

Constant orifice area damping (dashpot) provides the largest shock force at the beginning of the stroke when impact velocity is highest. These shock absorbers provide high-energy absorption in a small, economical design.

The internal structure of a single orifice shock absorber is shown above. When a force is applied to the piston rod, the check ball is seated and the valve remains closed. Oil is forced through the orifice, creating internal pressure allowing smooth, controlled deceleration of the moving load. When the load is removed, the compressed coil spring moves to reposition the piston head, the check ball unseats, opening the valve that permits rapid return of the piston head rod to the original extended position.

The closed cellular foam accumulator is compressed by the oil during the stroke, compensating for fluid displaced by the piston rod during compression. Without the fluid displacement volume provided by the foam accumulator, the closed system would be hydraulically locked.

Single-orifice shock absorbers provide constant orifice area (dashpot) damping.

Shock Absorbers

Example 1: Standard Products

10 **TK 10** **IF** - **2** **B**

Select quantity

Select catalog number

Select thread designation from engineering data chart (If applicable)

Select damping constant from appropriate sizing graph

Select piston rod type
• "-" (without button)
• "B" (with button)
• "CM" (Clevis mount)

Example 2: Custom Orifice Products*

10 **TK 21** **APPLICATION DATA**

Select quantity

Select catalog number

Specify:

- Vertical, rotary or horizontal motion
- Weight
- Impact velocity
- Propelling force (if any)
- Other (temperature or other environmental conditions)
- Cycles per hour

*Enidine will specify individual part number for each application.

Accessories

Example 1

10 **UF 3/4-16** Universal Mounting Flange
(P/N U120275095)

Select quantity

Select catalog/part number

Example 2

5 **UC 8609** Urethane Striker Cap
(P/N C98609079)

Select quantity

Select catalog/part number

Application Worksheet

FAX NO.: _____

DATE: _____

ATTN: _____

COMPANY: _____

The Enidine Application Worksheet makes shock absorber sizing and selection easier.

Fax, phone, or mail worksheet data to Enidine headquarters or your nearest Enidine subsidiary/affiliate or distributor. (See catalog back cover for Enidine locations, or visit www.enidine.com for a list of Enidine distributors.)

Upon Enidine's receipt of this worksheet, you will receive a detailed analysis of your application and product recommendations. (For custom design projects, Enidine representatives will consult with you for specification requirements.)

GENERAL INFORMATION

CONTACT: _____

DEPT/TITLE: _____

COMPANY: _____

ADDRESS: _____

TEL: _____ FAX: _____

EMAIL: _____

PRODUCTS MANUFACTURED: _____

APPLICATION DESCRIPTION

Motion Direction (Check One):

Horizontal Vertical Up Down Incline Angle _____ Height _____

Rotary Horizontal Rotary Vertical Up Down

Weight (Min./Max.): _____ (lbs.)(Kg)

Cycle Rate: _____ (cycles/hour)

Additional Propelling Force (If Known): _____ (lbs.)(N)

Air Cyl: Bore ____ (in.)(mm) Max. Pressure ____ (psi)(bar) Rod Dia.(in.)(mm)

Hydraulic Cyl: Bore ____ (in.)(mm) Max. Pressure ____ (psi)(bar) Rod Dia. ____ (in.)(mm)

Motor _____ (hp)(kW) Torque _____ (in-lbs.)(Nm)

Ambient Temp.: _____ °F (°C)

Environmental Considerations: _____

SHOCK ABSORBER APPLICATION (All Data Taken at Shock Absorber)

Number Shock Absorbers to Stop Load

Impact Velocity (min./max.): _____ (in./sec.)(m/sec.)

Shock Absorber Stroke Requirements: _____ (in.)(mm)

G Load Requirements : _____ (G)(m/sec²)

RATE CONTROL APPLICATION (All Data Taken at Shock Absorber)

Number of Rate Controls to Control the Load: _____

Control Direction: Tension (T) Compression (C)

Required Stroke: _____ (in.)(mm) Est. Stroke Time: _____ (sec.)

Estimated Velocity at the Rate Control: _____ (in./sec.)(m/sec)

Non-Adjustable Series Hydraulic Shock Absorbers

TK Micro-Bore Series

TK

Technical Data

TK 6M, TK 8 Series

Standard

Non-Adjustable Series

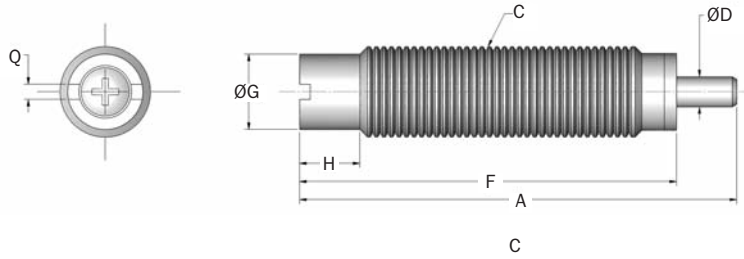

Catalog No./Model	Bore Size in. (mm)	(S) Stroke in. (mm)	(E _T) Max. in.-lbs./cycle (Nm/c)	(E _T C) Max. in.-lbs./hour (Nm/h)	(F _p) Max. Shock Force lbs. (N)	Nominal Coil Spring Force		Weight (mass) oz. (g)
						Extended lbs. (N)	Compressed lbs. (N)	
TK 6M	.28 (4,2)	.25 (4,0)	9 (1,0)	31,863 (3 600)	81 (360)	0.2 (1,0)	0.8 (3,5)	.14 (4)
TK 8M	.16 (4,2)	.25 (4,0)	9 (1,0)	42,480 (4 800)	81 (360)	0.2 (1,0)	0.8 (3,5)	.2 (6)

Catalog No./Model	Damping Constant	A in. (mm)	C in. (mm)	ØD in. (mm)	F in. (mm)	G in. (mm)	H in. (mm)	Q in. (mm)
TK 6M	-1, -2, -3	1.14 (29,0)	M6 x 0,5	.08 (2,0)	1.0 (25,0)	.20 (5,0)	.16 (4,0)	.04 (1,0)
TK 8M	-1, -2, -3	1.14 (29,0)	M8 x 1,0	.08 (2,0)	1.0 (25,0)	.25 (6,4)	.16 (4,0)	.04 (1,0)

Notes: 1. Dash numbers in page color are non-standard lead time items, contact Enidine.
2. A positive stop is required to prevent the bottoming of the TK 6 and TK 8 shock absorbers.

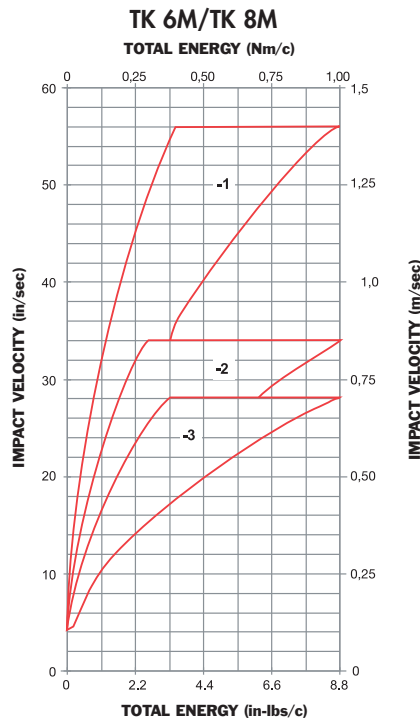

TK 10M Series

Standard

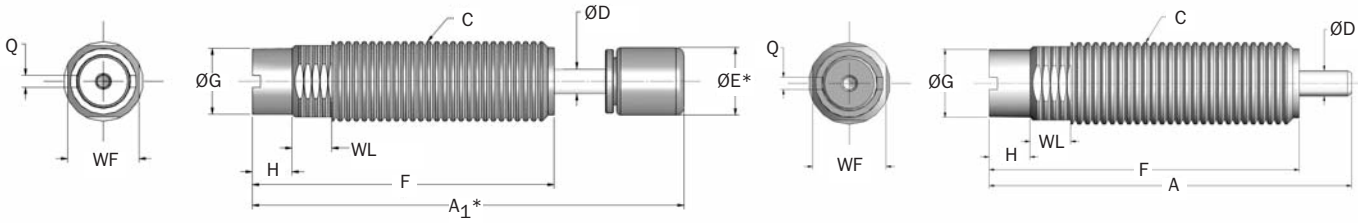

*Note: A₁ and E apply to button models and urethane striker cap accessory.

Catalog No./ Model	(S) Stroke in. (mm)	(E _T) Max. in.-lbs./cycle (Nm/c)	(E _T C) Max. in.-lbs./hour (Nm/h)	(F _P) Max. Shock Force lbs. (N)	Nominal Coil Spring Force Extended lbs. (N)	Compressed lbs. (N)	(F _D) Max. Propelling Force lbs. (N)	Weight (mass) oz. (g)
TK 10M (B)	.25 (6,4)	50 (6,0)	115,000 (13 000)	315 (1 400)	0.3 (1,5)	2.2 (10,0)	-	.6 (17)

Catalog No./ Model	Damping Constant	A in. (mm)	A ₁ in. (mm)	C in. (mm)	D in. (mm)	ØE in. (mm)	F in. (mm)	G in. (mm)	H in. (mm)	Q in. (mm)	WF in. (mm)	WL in. (mm)	Stroke (S) in. (mm)
TK 10M (B)	-1 to -9	1.75 (44,6)	2.14 (54,4)	M10 x 1,0 (3,1)	.12 (3,1)	.35 (8,5)	1.50 (38,0)	.33 (8,3)	.20 (5,0)	.06 (1,5)	.35 (9,0)	.16 (4,0)	0.25 (6,4)

Note: Dash numbers in page color are non-standard lead time items, contact Enidine.

TK 21M Series

Standard

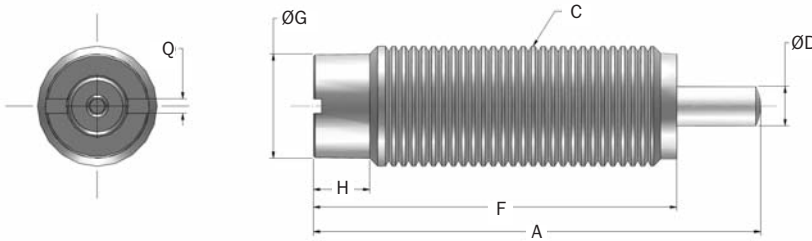

*Note: A₁ and E apply to button models and urethane striker cap accessory.

Catalog No./ Model	(S) Stroke in. (mm)	(E _T) Max. in.-lbs./cycle (Nm/c)	(E _T C) Max. in.-lbs./hour (Nm/h)	(F _P) Max. Shock Force lbs. (N)	Nominal Coil Spring Force Extended lbs. (N)	Compressed lbs. (N)	(F _D) Max. Propelling Force lbs. (N)	Weight (mass) oz. (g)
TK 21	.25 (6,4)	20 (2,2)	36,000 (4 100)	160 (700)	0.65 (2,9)	1.13 (5,0)	20 (89)	.4 (12)
TK 21M								

Catalog No./ Model	Damping Constant	A in. (mm)	C in. (mm)	D in. (mm)	F in. (mm)	G in. (mm)	H in. (mm)	Q in. (mm)
TK 21	-1, -2, -3	1.39 (35,4)	3/8 - 32 UNEF (9,5)	.12 (3,1)	1.13 (28,7)	.32 (8,2)	.17 (4,4)	.05 (1,2)
TK 21M	-1, -2, -3		M10 x 1,0 (3,1)					

Note: A positive stop is required to prevent the bottoming of the TK 21 shock absorber.

TK 10M

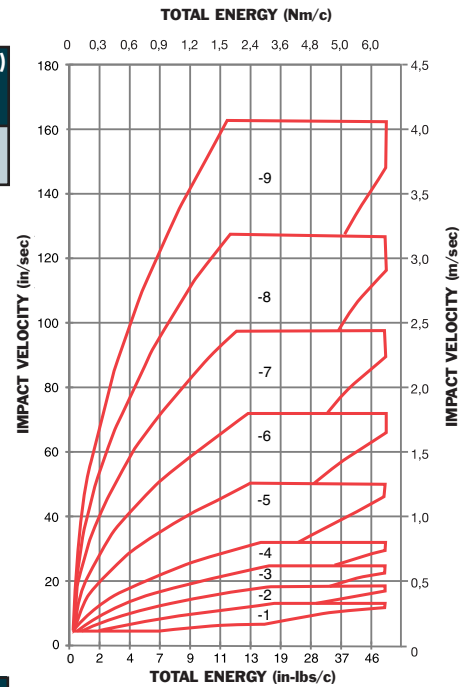

TK 21

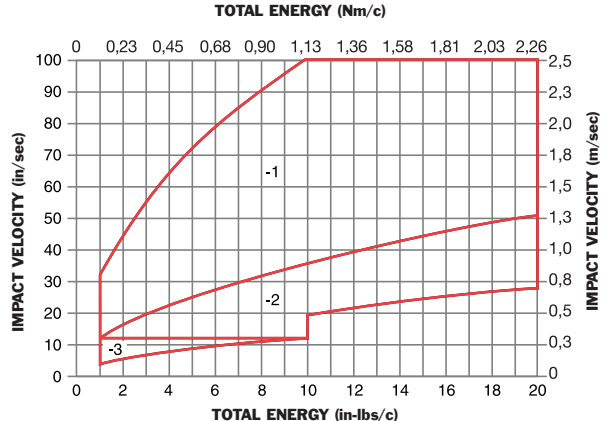

Non-Adjustable Series Hydraulic Shock Absorbers

STH Small-Bore Series

STH .25M → STH 1.5M x 2 Series

Custom Orificed Products

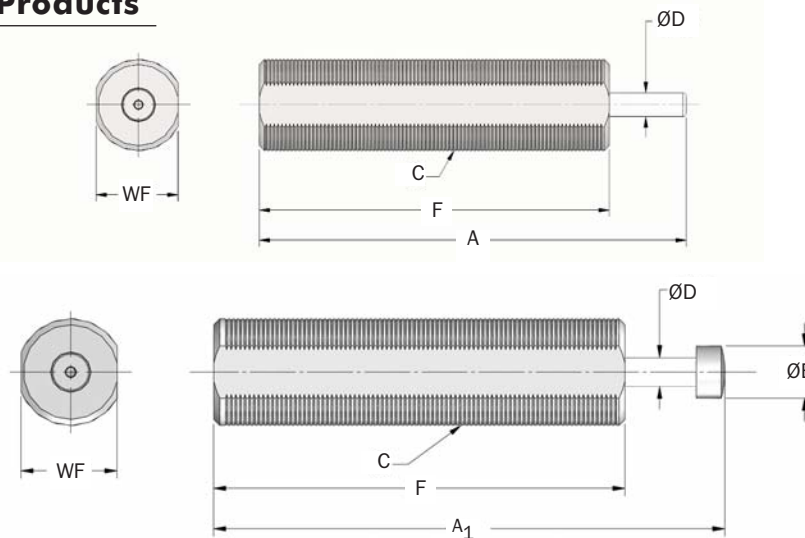

Catalog No./ Model	(S) Stroke in. (mm)	(E _T) Max. in.-lbs./cycle (Nm/c)	(E _T -C) Max. in.-lbs./hour (Nm/h)	(F _P) Max. Shock Force lbs. (N)	Nominal Coil Spring Force		Model Weight lbs. (g)
					Extended lbs. (N)	Compressed lbs. (N)	
Δ STH .25M	0.25 (6,0)	100 (11)	39,000 (4 420)	615 (2 730)	2.5 (11)	4.0 (18)	2.8 oz. (79)
Δ STH .5M	0.50 (12,5)	585 (65)	390,000 (44 200)	1,800 (8 000)	4.0 (18)	7.0 (31)	7.7 oz (218)
Δ STH .75M	0.75 (19,0)	2,180 (245)	780,000 (88 400)	4,400 (19 600)	8.0 (35)	20.0 (90)	1.1 (500)
Δ STH 1.0M	1.00 (25,0)	4,400 (500)	1,300,000 (147 000)	6,700 (29 800)	22.0 (98)	53.0 (235)	1.6 (726)
Δ STH 1.0M x 2	2.00 (50,0)	8,800 (1 000)	2,100,000 (235 000)	6,700 (29 800)	15.0 (66)	30.0 (133)	1.9 (862)
Δ STH 1.5M x 1	1.00 (25,0)	10,200 (1 150)	2,200,000 (250 000)	14,600 (65 000)	20.0 (90)	51.0 (227)	3.1 (1 400)
Δ STH 1.5M x 2	2.00 (50,0)	20,400 (2 300)	3,200,000 (360 000)	14,600 (65 000)	12.5 (56)	51.0 (227)	4.0 (1 800)

- Notes: 1. Custom orificed application data needed.
 2. All shock absorbers will function at 5% of their rated energy per cycle. If less than 5%, a smaller model should be specified.
 3. Enidine recommends a positive stop to prevent bottoming of the shock absorber.
 4. Δ = Non-standard lead time items, contact Enidine.

Catalog No./ Model	A in. (mm)	A ₁ in. (mm)	C in. (mm)	D in. (mm)	E in. (mm)	F in. (mm)	WF in. (mm)
STH .25M	—	2.81 (71,0)	M14 X 1.0	.19 (4,8)	.50 (12,7)	2.00 (51,0)	.50 (13,0)
	—	3.50 (89,0)	M22 X 1.5	.22 (5,6)	.38 (9,5)	2.70 (68,5)	.88 (20,0)
STH .5M	—	5.13 (130,0)	M30 X 2.0	.31 (8,0)	.56 (14,3)	4.06 (103,0)	1.13 (27,0)
	—	6.70 (170,0)	M36 X 1.5	.38 (9,5)	.69 (17,5)	5.38 (136,5)	1.25 (32,0)
STH 1.0M	—	9.38 (238,2)	M36 X 1.5	.38 (9,5)	.69 (17,5)	7.02 (178,3)	1.25 (32,0)
	—	7.09 (180,0)	M45 X 1.5	.63 (16,0)	—	6.06 (154,0)	1.63 (42,0)
STH 1.0M x 2	—	10.63 (270,0)	M45 X 1.5	.63 (16,0)	—	8.62 (219,0)	1.63 (42,0)
	—	—	M45 X 1,5	—	—	—	—

TK 10 → STH 1.5M x 2 Series

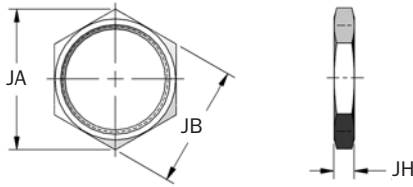
Jam Nut (JN)

Catalog No./Model	Part Number	Model (Ref)	JA in. (mm)	JB in. (mm)	JH in. (mm)	Weight (mass) oz. (g)
JN 3/8 - 32	J14421034	TK 21	.58 (14,7)	.50 (12,7)	.09 (2,2)	0.1 (2,8)
JN M10 x 1	J24421035	TK10M/TK21M	0.59 (15,0)	0.51 (13,0)	.13 (3,2)	0.1 (2,8)
JN M14 x 1	J24950035	STH .25M	.77 (19,7)	.67 (17,0)	.16 (4,0)	0.2 (3)
JN M22 x 1.5	J26402035	STH .5M	1.24 (31,5)	1.06 (27,0)	.22 (5,5)	0.5 (12)
JN M30 x 2	J230583035	STH .75M	1.63 (41,6)	1.42 (36,0)	.27 (7,0)	0.9 (26)
JN M36 x 1.5	J23164035	STH 1.0M	1.86 (41,6)	1.61 (36,0)	.25 (7,0)	0.9 (26)
JN M36 x 1.5	J23164035	STH 1.0 X 2M	1.86 (41,6)	1.61 (36,0)	.25 (7,0)	0.9 (26)

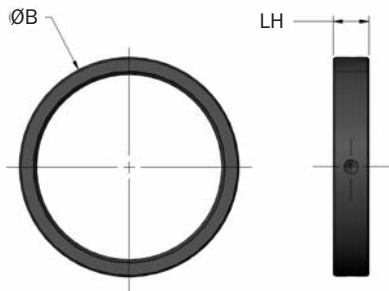
Lock Ring (LR)

Catalog No./Model	Part Number	Model (Ref)	B in. (mm)	LH in. (mm)	Weight (mass) oz. (g)
LR M45 x 1.5	F88637049	STH 1.5 Series	2.25 (57,2)	.38 (9,5)	2.0 (75)

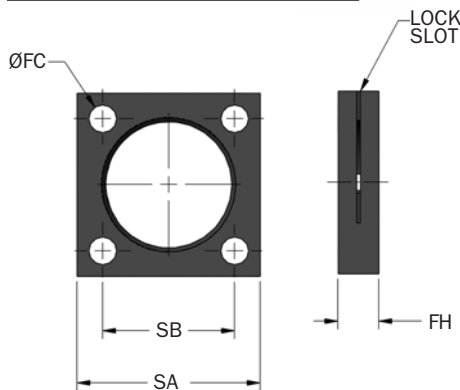
Square Flange (SF)

Catalog No.	Part Number	Model (Ref)	FC in. (mm)	FH in. (mm)	SA in. (mm)	SB in. (mm)	Bolt Size in. (mm)	Weight (mass) oz. (g)
SF M45 X 1.5	M48637129	STH 1.5 Series	.34 (8,6)	.50 (12,7)	2.25 (57,2)	1.63 (41,3)	3/16 (M8)	5 (142)

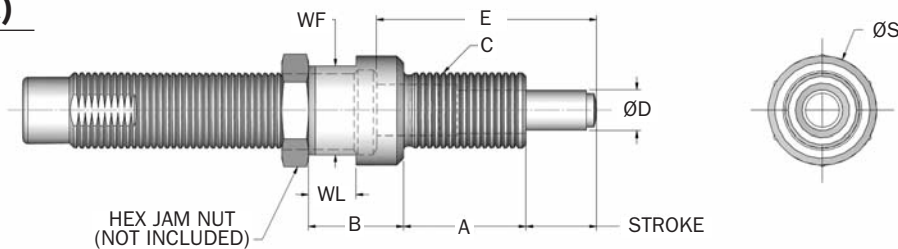
Side Load Adapter (SLA)

Catalog No./Model	Part Number	Model (Ref)	Stroke in. (mm)	A in. (mm)	B in. (mm)	C in. (mm)	D in. (mm)	E in. (mm)	S in. (mm)	WF in. (mm)	WL in. (mm)
SLA 3/8 - 32 x .25	SLA 33843	TK 21	.26 (6,6)	.47 (12)	.43 (11)	3/8 - 32 UNEF	.20 (5,0)	.85 (21,6)	.51 (13,0)	.44 (11,0)	.16 (4,0)
SLA 10 MF	SLA 33457	TK 10M/TK 21M	.27 (6,9)	.47 (12)	.43 (11)	M10 x 1 M10 x 1	.20 (5,0)	.85 (21,6)	.51 (13,0)	.43 (11,0)	.16 (4,0)

Notes: 1. Maximum sideload angle is 30°. 2. Dash number in page color are non-standard lead time items, contact Enidine.

Non-Adjustable Series Hydraulic Shock Absorbers

TK, STH Micro-Bore Series

Accessories

TK 10 → STH 1.5M x 2 Series

Rectangular Flange (RF)

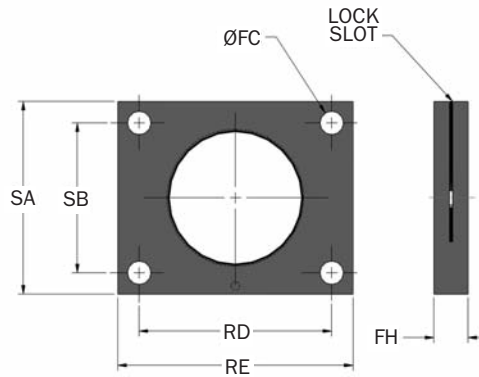

Catalog No./ Model	Part Number	Model (Ref)	A in. (mm)	FC in. (mm)	FH in. (mm)	RD in. (mm)	RE in. (mm)	SA in. (mm)	SB in. (mm)	Bolt Size in. (mm)	Wt. (mass) oz. (g)
RF M45 x 1.5	M58637053	STH 1.5 Series	M45 x 1.5	.34 (8,6)	.50 (12,7)	2.38 (60,5)	3.00 (76,2)	2.25 (57,2)	1.63 (41,3)	⁵ / ₁₆ (M8)	9 (142)

Universal Retaining Flange (UF)

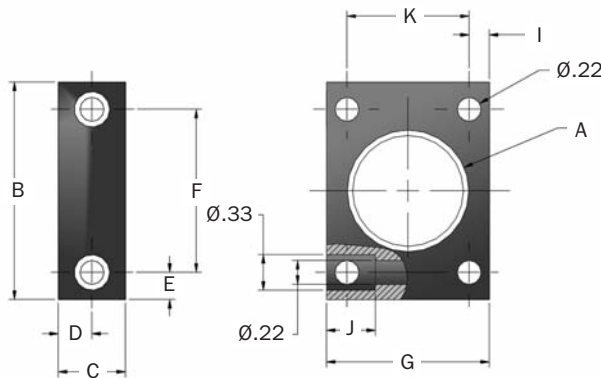

Catalog No./ Model	Part Number	Model (Ref)	A in. (mm)	B in. (mm)	C in. (mm)	D in. (mm)	E in. (mm)	F in. (mm)	G in. (mm)	H in. (mm)	J in. (mm)
UF M10 x 1	U16363189	TK 10M(B)/TK21M	M10 x 1	1.50 (38,0)	.47 (12,0)	.24 (6,0)	.25 (6,25)	1.00 (25,5)	1.00 (25)	.50 (12,5)	.20 (5)
UF ³ / ₈ - 32	U19070095	TK21	³ / ₈ - 32 UNF	1.50	.56	.28	.25	1.00	1.00	.50	.20

Non-Adjustable Series